

# DESTONER SGA-B

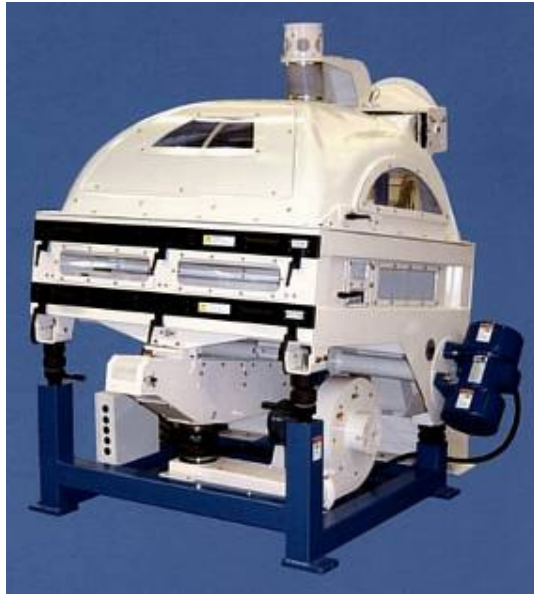

The Satake Destoner simplifies the cleaning of cereal grains such as wheat, rye, barley and rice. It can also be used for the cleaning of nuts and pulses.

It separates the material into three groups by density:

1. Stones and other heavy impurities
2. Clean grain/product
3. Dust

The Satake Destoner is a robust machine, easy to set and designed for trouble free operation.

## Unique Stone Discharge & Resort Mechanism

The discharged stone from primary sieves contains some good product. This mixed fraction is sent to the secondary sieve using blowing air from a built-in fan where stones are concentrated and discharged.

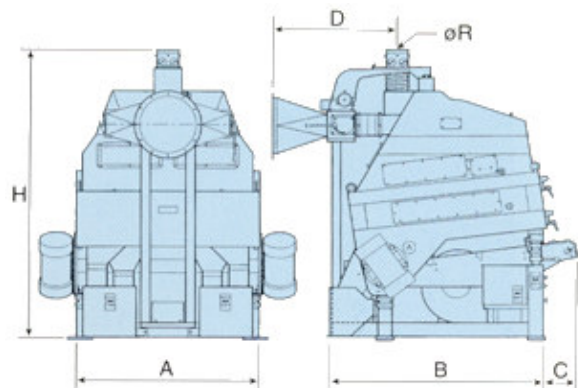
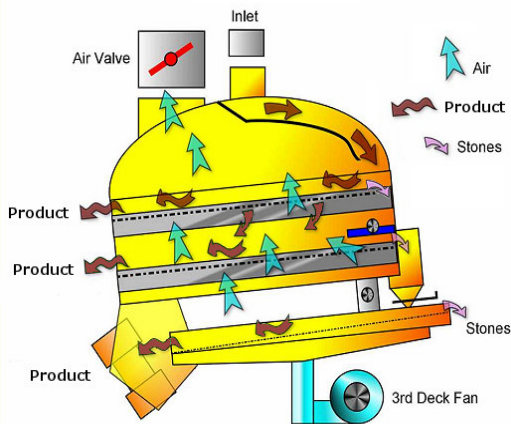

Model	SGA5B	SGA10B	SGA15B
Capacity – Brown Rice	5 t/h	10t/h	15 t/h
Required Power Supply	Vibratory Motor	0.37kWx2	0.37kWx2
	Fan	0.75kW	0.75kW
Approximate Weight	500kg	600kg	800kg
Exhaust Air Required M <sup>3</sup> /min	80 ~ 90	120 ~ 140	180 ~ 210
Exhaust Static Pressure	-60 ~ -70 mm Aq		

Dimensions: mm

Model	A	B	C	D	H	R
SGA5B	797	1,430	235	853	1,979	6"
SGA10B	1,240				2,029	
SGA15B	1,872				2,179	

All Satake products are the subject of continuous development and, as a result, their specification may change and differ in detail from that outlined in this leaflet.

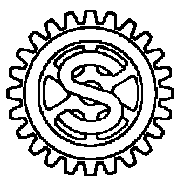

**SATAKE AUSTRALIA Pty Ltd**  
15 Leland Street  
Penrith  
NSW 2750  
Australia

Telephone: +61 (0) 2 4725 2600  
Facsimile: +61 (0) 2 4725 2601  
E-mail: [info@satake.com.au](mailto:info@satake.com.au)  
Website: [www.satake.com.au](http://www.satake.com.au)

