

Multi Purpose Belt Type Optical Sorter



CSV600BI / CSV600BM



CSV600BM

SATAKE CORPORATION

Specifications

Model	CSV600BI	CSV600BM
NIR Sorting	—	○
Capacity *1	0.1~6.0 (Soybean) t/h	
Subject Material *2	Beans, Tree Nuts, Seeds, Food (Snacks, etc.), Industrial Material (Recycle Plastic, etc.)	
Raw Material Supply	Removable Electromagnetic Feeder	
Belt	Material	Polyurethane (Meets Japanese Food Sanitation Law)
	Effective Size	Width: 650 mm, Length: 1,680 mm
Optics	Camera	Full Color CCD × 4
	Lighting	White LED × 6
Ejector Valve	QTY 136 5mm Pitch	
Cleaning Device	Wiper, Sweeper	
Power Requirement	2.0kW Max. (AC200~220V Single Phase)	
Air Consumption	1,000~1,500Nℓ/min	
Required Air for Optional Dust Collection *3	10m ³ /min	
Net Weight	Approx. 800 kg	
Optional Parts	(1)Flow Straightener, (2)Reject chute with dust collector connection (3)Heater, (4)Blower, (5)Buffer Sheet for Accept chute	

*1 Sorting performance varies depending on variety and contamination of material.

*2 May not be able to sort due to the characteristics of material.

*3 Dust collection system may be required depending on the material.

Dimensions (mm)

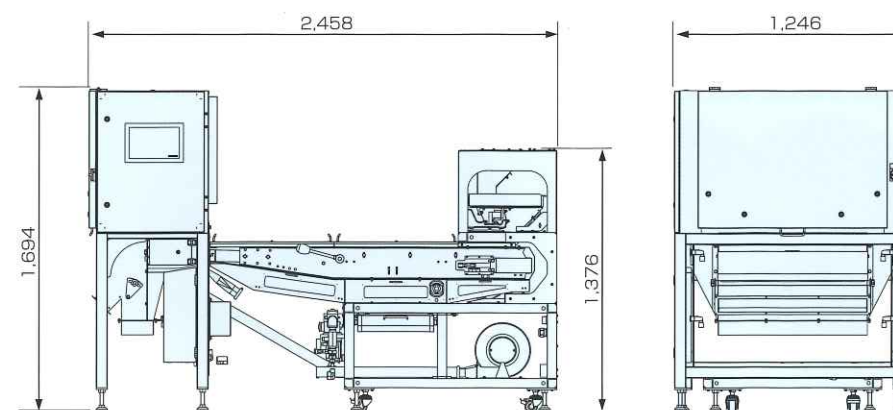

All Satake products are the subject of continuous development and, as a result, their specification may change and differ in detail from those shown.

SATAKE CORPORATION

Head Office
2-30 Saijo Nishihonmachi,
Higashi-Hiroshima-shi, Hiroshima-ken,
739-8602, Japan
URL : www.satake-group.com

Korea Branch
Alpha mighty Dunsan Building, 13F,
229, Daedeck-daero, Seo-gu, 35229
URL : www.satake-group.com

SATAKE USA INC.
10900 Cash Road,
Stafford, Texas, 77477, U.S.A.
URL : www.satake-usa.com

SATAKE AMERICA LATINA LTDA.
Rua Xavantes, 155-Pav. 20, Bairro
Atradores, CEP 89203-210, Joinville,
Santa Catarina, Brazil
URL : www.satake.com.br/

SATAKE EUROPE LTD.
P.O. Box 53, Horsfield Way, Bredbury
Industrial Park, Bredbury, Stockport,
Cheshire, SK6 2SU, U.K.
URL : www.satake-europe.com

SATAKE INDIA ENGINEERING PVT. LTD.
4th Floor, Tower-1, HB Twin Towers, A2,
3, 4, Netaji Subhash Place, Wazirpur
District Centre, New Delhi, 110034, India
URL : www.satakeindia.com/

SATAKE (THAILAND) CO., LTD.
133,134 Moo 5, Bangkadi, Mueang
Pathum Thani, Pathum Thani 12000,
Thailand
URL : www.satake-th.com

SATAKE ASIA CO., LTD.
888/84 Mahatun Plaza Bld., 8th Floor,
Ploenchit Rd., Lumpini, Pathumwan,
Bangkok, 10330, Thailand
URL : www.satake-th.com

PT. SATAKE GOBEL INDONESIA
Gedung Surabaya Bumi Mandiri,
Lantai 9, Jalan Jenderal Basuki
Rachmat Nomor 129-137, Unit 905 B,
Indonesia

SATAKE MANUFACTURING (SUZHOU) CO., LTD.
229 Jin Feng Road, Suzhou New
District, Suzhou, Jiangsu Province,
215129, China
URL : www.satake.cn/

SATAKE AUSTRALIA PTY. LTD.
15 Leland Street, Penrith, N.S.W.,
2750, Australia
URL : www.satake.com.au

ISO 9001 Certification
(Quality Management Systems)

SATAKE CORPORATION has obtained
ISO9001 and ISO14001 certification.
These international standards for management
systems ensure Satake will continue to provide
high quality products and services.

ISO 14001 Certification
(Environmental Management Systems)

Multi-Purpose Belt Sorter with NIR Sorting, Shape Recognition, Smart Sensitivity, and More...

Color-NIR Full-Color + NIR

NIR Camera(CSV600BM)

NEW!

Full Color Camera

Back Ground LED

Belt Conveyor

LED

Ejector

Full Color Camera

Back Ground LED

Reject

Accept

Bean (White Kidney)

Accept Foreign Material

NIR camera detects inorganic foreign material such as stone, plastics and glasses having similar color to good product.

The belt stably and uniformly conveys the material, ensuring high sorting accuracy. The improved LED lightning captures the slightest color differences via sensors. Defective products are ejected from the product stream by air. Detachable components are made of stainless steel for higher hygiene standards.

Sorting Various Products

BELTUZA's lower belt speed can handle lighter materials resulting in a much wider range of product handling.

<p>Soy</p> <p>Accept Reject</p>	<p>Green Soybean</p> <p>Accept Reject</p>	<p>Coffee</p> <p>Accept Reject</p>
<p>Red Bean</p> <p>Accept Reject</p>	<p>Olive</p> <p>Accept Reject</p>	<p>Seed</p> <p>Accept Reject</p>

Shape Recognition

Abnormal shapes such as broken and connected product can be sorted by the "Shape Recognition" technology. Less damage to the product than mechanical separation resulting in higher yield.

Pasta

Accept Reject

Easy Sensitivity Setting

Satake's original automatic sensitivity creation system allows the users to adjust the sort setting easily in every material.

- 1 Scan the accepts image with full color camera.
- 2 Scan the rejects image, and press "Create Profile" button.
- 3 Optimum sensitivity setting is automatically created.

Feature

<p>Usability</p> <p>Easy Operating Touch Panel</p>	<p>Maintenance</p> <p>Easy Sanitation</p>	<p>Economical</p> <p>Long Lifetime LED Lighting</p>
---	--	--

Screen can be operated with the same actions as smart-phones. Excellent visual screen design provides user-friendly operation.

The machine body is a dividable structure for easy cleaning and maintenance. Belt conveyor is easy to remove.

LED lighting is applied for optical section. It's lifetime is ten times longer compared with our existing fluorescent lamps.

Components

Belt conveyor

The belt conveyor smooths out the material flow, making high capacity delivery possible even for larger materials of irregular shape.

Removable Feeder

A stainless steel body frame and removable parts provide easy cleaning and sanitation. BELTUZA's vibratory feeder can be removed for flexible product line layout.