

# WATER CONTROL PANEL SWEC



SWEC Panel with Litres/min Controller

The SWEC Water Panel controls and monitors the flow rate of water using all electronic components. The main use is in the addition of water to wheat and other cereal grains before milling.

Two model types are available:

1. Actual flow rate set in litres or gallons per minute
2. Flow rate set as percentage of maximum

The host PLC connects into the terminal box and sends the target flow rate or percentage setting and open/close signals to the SWEC. The SWEC returns the actual flow rate value to the PLC.

At the inlet there is a pressure regulator to control the incoming water pressure. An electrically operated solenoid valve starts and stops the flow of water dependent on the open/close signal from the host PLC.

An electronic flow rate monitor displays the actual water flow rate and returns this value to the host PLC.

SWEC Water Control Panel

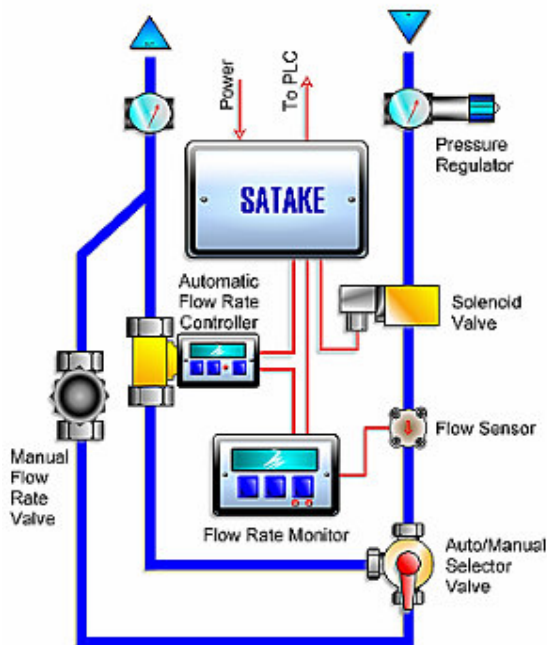

Diagram of SWEC Panel with Litres/Minute Controller

The SWEC assembly is mounted on a stainless steel panel and can also be used to control the flow rate of other liquid products such as additives, oils and chemicals.

A 2-Way selector valve allows the operator to choose to operate the system in semi-automatic or fully automatic modes. In semi-automatic the host PLC will send an open/close signal to the solenoid valve and the flow detector will return the actual flow rate value but the operator will set the flow rate using the variable manual control valve. In fully automatic mode the host PLC will send a target flow rate to the automatic flow rate controller.

For hard wired control systems, manual setting of litres/minute can be achieved by setting a toggle switch in the wiring box to manual and setting the water flow rate using the controller mounted on the panel.

Type	Water Flow Rate Ltrs/Hour	Automatic	Manual
SWEC 150	15-150	✓	✓
SWEC 900	60-900	✓	✓
SWEC 1400	250-1400	✓	✓

All Satake products are the subject of continuous development and, as a result, their specification may change and differ in detail from that outlined in this leaflet.

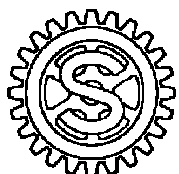

**SATAKE AUSTRALIA Pty Ltd**  
15 Leland Street  
Penrith  
NSW 2750  
Australia

Telephone: +61 (0) 2 4725 2600  
Facsimile: +61 (0) 2 4725 2601  
E-mail: [info@satake.com.au](mailto:info@satake.com.au)  
Website: [www.satake.com.au](http://www.satake.com.au)