

# OM SERIES

## Open Mouth Bag Scale

The OM Series scale utilizes Taylor Products' patented beam scale and is self dampening, and the weight pointer and calibration adjustment are located directly on the beam. The OM Series flow control regulates the speed of material going through the scale. The series includes both manual mechanical and automatic air/electric models.

### Simple but Accurate Weighing on Patented Beam Scale Design

- Up to 12 bags per minute
- 15 lb to 125 lb capacity
- Granules
- Feed
- Seed
- Grain

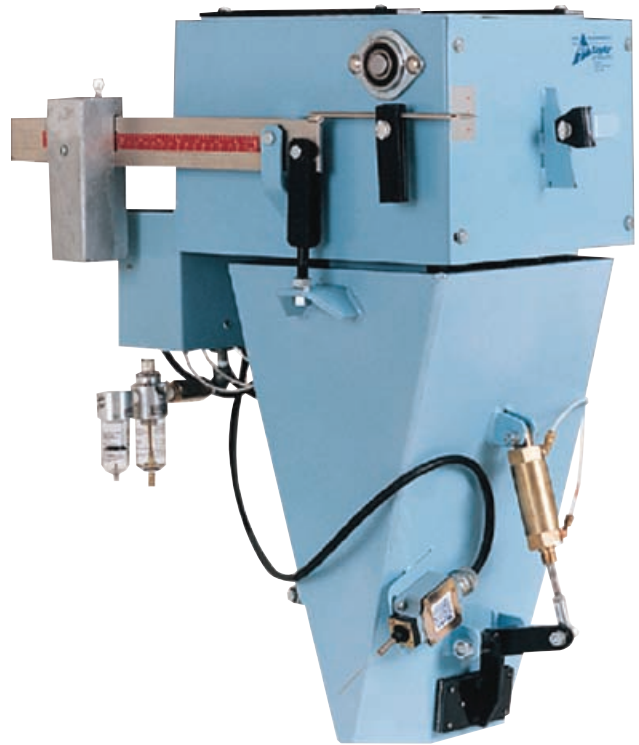

# Specifications OM SERIES



Diagram dimensions are for reference only

## OM2A AUTOMATIC / BEAM

## OM2 MANUAL / BEAM

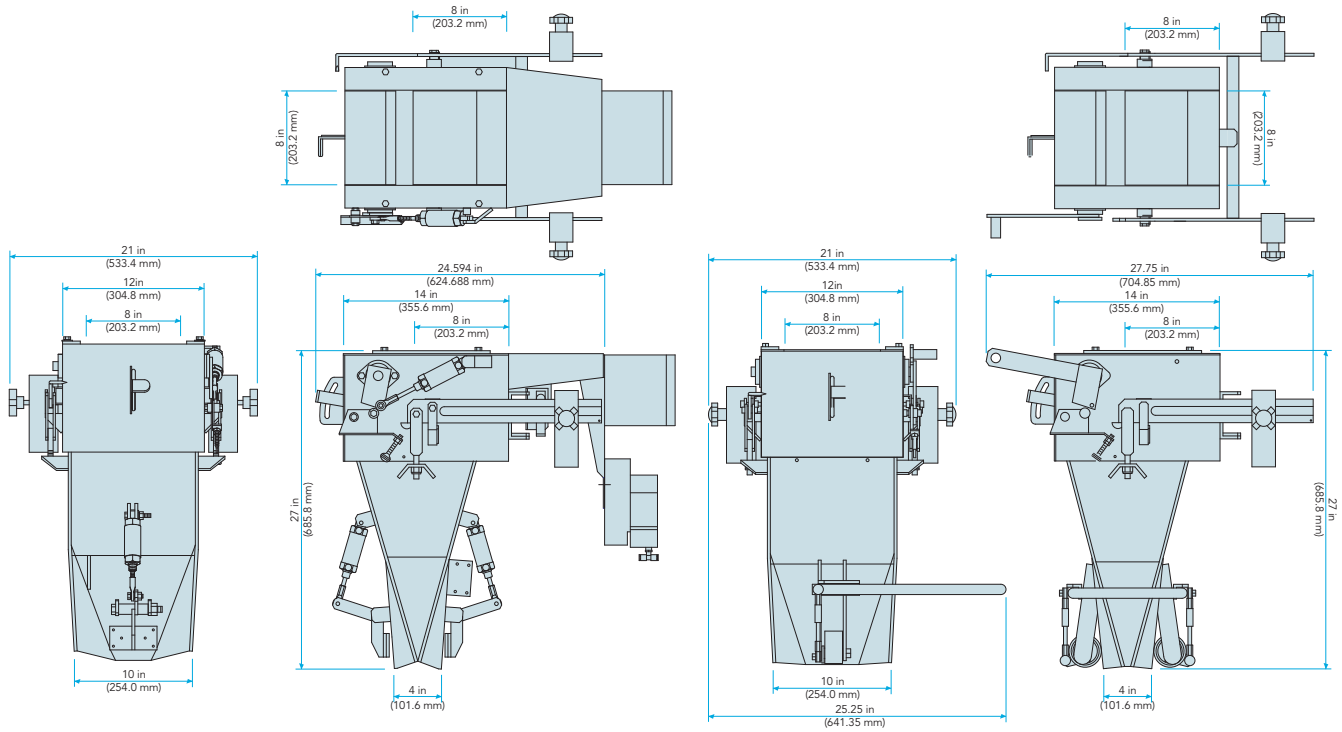

**Dimensions** 30.0 in x 25.0 in x 27.0 in (762 mm x 635 mm x 685.8 mm)

**Speed** Up to 12 BPM

**Accuracy** ± 0.4 lb

**Weight Range** 15 – 125 lbs

**Scale** Beam

**Construction** Carbon Steel Blasted and Painted

**Electrical Requirements** 115 V, single phase (on OM2A only)

**Air Requirements** 100 psi, 2 cfm (on OM2A only)

**Popular Options** Stainless Steel Construction, Shock Absorber, Belt Feeder, Valve Bag Adapter

Note: Equipment selection may be verified in the Taylor Products test lab.



©2007 Magnum Systems, Inc. All rights reserved. Catalog number: MS.1034.0807