

**SATAKE**

# MAIZE DEGERMER VBF



*VBF with optional control panel*

The new Satake VBF series of vertical maize (corn) degerming machines incorporate the most advanced techniques and has proved to be superior to other machines in maize degerming mills throughout the world. The versatility of the VBF for decorticating and degerming of all kernels makes it the ideal machine for modern maize mills.

**VBF Features:**

1. Higher Degerming Yield – The newly developed degerming chamber produces evenly decorticated and degerming maize with higher yield
2. Lower Installation and Operation Costs – The VBF’s robust construction and low specific power minimizes operating costs. Its compact design minimizes floor space requirements and installation costs
3. Easy Maintenance – The screens and two piece degerming roll are easily removed from the side of the machine
4. One Touch Discharge of Remaining Maize (option) – The maize remaining in the chamber after degerming can be easily discharged by using the optional suction fan system

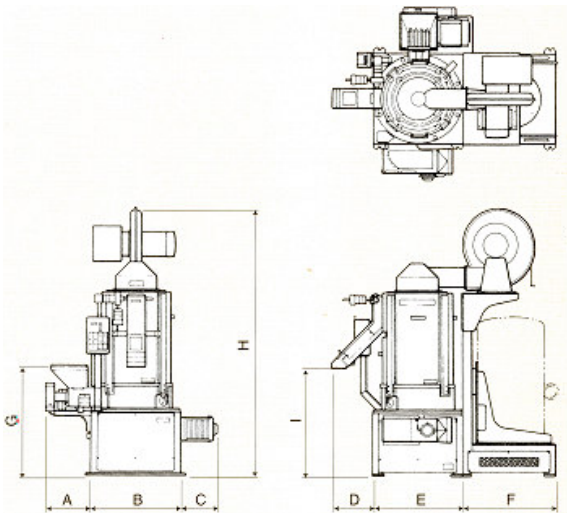

Model	Input Capacity t/h	Motor kW	Main Shaft rpm	Air Volume m <sup>3</sup> /min	Static Pressure mmAq	Net Weight kg
VBF5A	2~3	22	480	35	-100~-150	900
VBF7B	3~4	37	480	40	-100~-150	1,000
VBF10A	4~7	55,75	480	45	-100~-150	1,300

\*Capacity is dependent upon the application and product quality required

**DIMENSIONS (MM)**

Model	A	B	C	D	E	F	G	H	I
VBF5A	363	730	301	210	730	700	800	1901	760
VBF7B	363	730	301	210	730	700	800	2010	865
VBF10A	375	730	304	329	730	730	890	2177	880

All Satake products are the subject of continuous development and, as a result, their specification may change and differ in detail from that outlined in this leaflet.

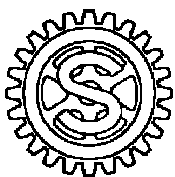

**SATAKE AUSTRALIA Pty Ltd**  
 15 Leland Street  
 Penrith  
 NSW 2750  
 Australia

Telephone: +61 (0) 2 4725 2600  
 Facsimile: +61 (0) 2 4725 2601  
 E-mail: [info@satake.com.au](mailto:info@satake.com.au)  
 Website: [www.satake.com.au](http://www.satake.com.au)